

Networked control of identical subsystems

Ozan Demir
demir@atp.rub.de

1 Introduction

This project is devoted to interconnected systems consisting of identical subsystems, where the subsystems are controlled by associated local controllers (Fig. 1). With the use of a communication network, information among the subsystems can be exchanged, whenever the exchanged information can be used to improve the system performance. The subsystem interactions are either caused by the physical relations between the subsystems or have to be introduced by the networked controllers to deal with the cooperative (shared) control goals.

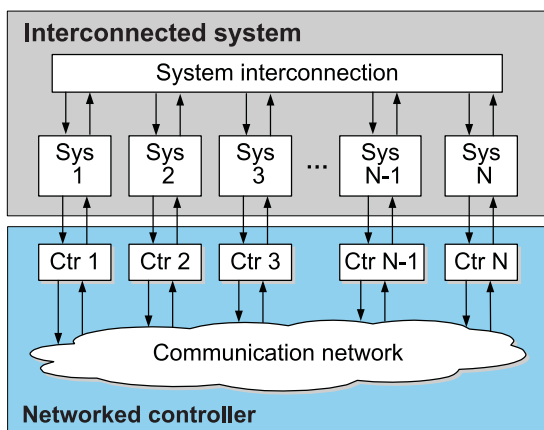

Figure 1: Networked control of interconnected systems

2 Interconnection Structures

Physically interconnected systems consist of the subsystems with individual control goals. Consequently, even a decentralized controller can (usually) fulfill the control goals but using an information exchange among the subsystems, the overall system performance can be improved. Examples for physically interconnected systems with similar subsystems are electric power networks, multizone furnaces or adaptive optics. In the course of this project, several interconnection structures are considered: serially coupled systems, symmetrical composite systems, locally coupled systems.

Multi-agent systems are composed of physically decoupled subsystems (often referred to as agents), which interact over the controllers with other subsystems to accomplish a common (cooperative) goal. Examples for cooper-

ative control goals are moving (or flying) in a specific formation (formation control), distributing itself evenly over a desired region (sensor networks) or reaching an agreement on a state or information in a distributed way (consensus and synchronization problems). An information exchange among the subsystems is necessary to complete cooperative tasks which are beyond the abilities of single subsystems.

3 Project aims

3.1 Offline information reduction

The interconnected system may display a rich and complex behavior, particularly if the number of the subsystems is large. A natural way to deal with the complexity of the controller design problem is to apply a **decomposition** strategy with the intention of decomposing the controller design problem for the overall system into smaller problems, which can be solved in a more efficient way. Consequently, the overall system model will be not required for the controller design.

In this project, a decomposition strategy based on a state transformation is introduced. The proposed decomposition approach can be applied uniformly to multi-agent systems and physically interconnected systems. The only assumption to apply the decomposition approach is that the interconnection matrix is diagonalizable. After the state transformation, the controller design can be performed considering the (modified) subsystems independently, which contain information on the system interconnection and have the order of a single subsystem.

In [2], a controller design strategy is introduced, so that the distributed controller can be determined by solving a single ARE for a modified subsystem. The designed distributed controller has the same structure as the interconnected system and guarantees for an arbitrary initial condition a better performance than the decentralized controller.

3.2 Online information reduction

It is obvious that the optimal system performance will be achieved with a centralized controller structure which requires a continuous communication among all subsystems. In this project, alternative control strategies have been introduced, which reduce the communication load while a certain degree of the optimal performance is still guaranteed.

3.2.1 Control of the interconnected systems with situation dependent communication

In order to reduce the communication load, the information exchange will be only temporarily invoked among the local controllers. Hence, the subsystems operate in two modes:

- **Autonomous mode:** The subsystems have autonomous controllers that do not interact with each other and are designed to meet individual aims of the subsystems.
- **Cooperative mode:** The local controllers exchange information over the digital network in order to improve the overall system behavior.

In order to reduce the communication effort further, the information exchange is only performed among the directly interconnected systems. Consequently, a distributed controller with the same structure as the interconnected system arises. The distributed controller must not only ensure the stability of the interconnected system but must also provide a better performance compared with the decentralized controller.

3.2.2 Control of the interconnected systems with event-based communication

The main idea of the event-based control is to approximate the closed-loop system behavior by a continuous state-feedback controller with a reduced communication. The need for an information exchange is reduced by the estimation the future behavior of the neighbor subsystems. The information exchange is invoked only when the difference between the estimated and current subsystem state exceeds an event threshold. Consequently, the communication effort will be reduced, while the computational effort increases, since additional system models must be incorporated in the controllers in order to perform the state estimation.

The controller structure is depicted in Fig.2 where the solid lines represent continuous communication between the local controllers and agents while the dotted links represent the event-based communication among the subsystems.

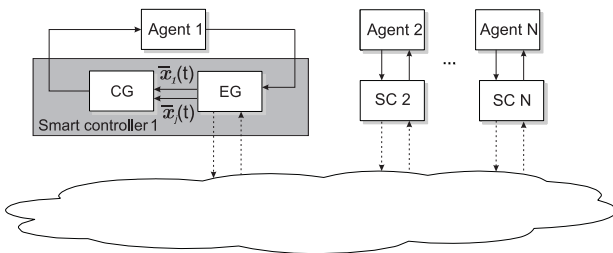

Figure 2: Networked control of interconnected systems with event based communication

4 Application examples

4.1 Synchronisation of identical agents with event-based communication

A part of the literature on the multi-agent systems is focused on the synchronization and consensus of multi-agent systems. In [1], a new synchronization schema has been introduced, where event-based communication is used as a means to reduce the communication effort. It is assumed that a state feedback controller with continues communication ensures the asymptotic synchronization of the overall system. The event-based controller guarantees that the agents converge to a bounded region around the synchronous trajectory with the continuous state-feedback controller. The deviation of the agents from the synchronous trajectory depends on the event threshold and can be made arbitrary small at the cost of a more frequent communication. The asymptotic synchronization will be achieved with the event based controller, only when a broadcast communication is allowed.

4.2 Multizone crystal growth furnace

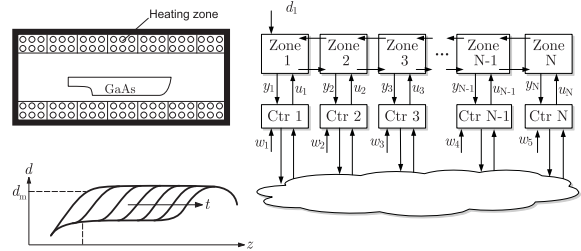

Figure 3: Multizone furnace for crystal growth

The multizone furnace in Fig. 3 presents an application example with locally interconnected subsystems. It is used to grow GaAs crystals with the highest possible purity. Firstly, the crystal in the middle of the furnace is heated up over the melting point. Then, it is cooled down in a coordinated way, e. g. from left to right, so that the foreign substances will float to the end of the crystal.

The strength of the physical coupling between the heating zones depends on the temperature difference. While heating up, the temperature difference is small. Consequently, a decentralized controller can provide the desired system performance. While cooling down, the temperature difference between neighbor zones grows which makes an information exchange among the subsystems necessary.

References

- [1] O. Demir and J. Lunze: Event-based synchronisation of multi-agent systems. In *Proc. of the 4th Conference on Analysis and Design of Hybrid Systems, Eindhoven, Netherlands, (2012)*.
- [2] O. Demir and J. Lunze: A decomposition approach to decentralized and distributed control of spatially interconnected systems. In *Proc. of the 18th IFAC World Congress, Milano, Italy, (2011)*.